

EKO KOMUNAL

MODERNA KOMUNALNA
VOZILA 2024

DESIGNS - MANUFACTURES - DELIVERIES

MODERN
UTILITY VEHICLES

SPRJEČAVANJE
NASTAJANJA OTPADA

PONOVNA
UPORABA

RECIKLIRANJE
KOMPOSTIRANJE

ENERGETSKA
OPORABA

ODLAGANJE



PROJEKTIRA - PROIZVODI - ISPORUČUJE

Tehnix®



Specijalizirane TEHNIX proizvodne hale za proizvodnju komunalnih vozila



SERVIS

Tomislav Matošić ing. el.
+385 98 388 395
servis@tehnix.com

Milivoj Priher mag. oec.
+385 99 538 2081
ekomunal@ekomunal.com

Nikola Madić
+385 98 303 787
tehnix@tehnix.com

TEHNIČKI KONTAKT

Denis Pavlic mag. ing. mech.
+385 99 492 2758
denis.pavlic@tehnix.com

Zoran Kalšan ing. el.
+385 99 232 7828
zoran.kalsan@tehnix.com

Nikola Golub ing. str.
+385 99 324 3590
nikola.golub@tehnix.com



POSLOVNI KONTAKT

Vlado Balent menadžer specijalist
+385 98 241 787
vlado.balent@tehnix.com

Igor Habuš dipl. oec., menadžer
+385 99 346 8825
igor.habus@tehnix.com

Željko Horvat dipl. ing. str., predsjednik uprave
zeljko.horvat@tehnix.com

Već više od tri desetljeća kompanija Tehnix isporučuje inovativne proizvode, opremu i tehnologije za mnoge projekte u Hrvatskoj, Europi i širom svijeta te na taj način obogaćuje društvo, poboljšava kvalitetu života i ima pozitivan utjecaj na okoliš i tehnološke standarde industrije. Osnivač, vlasnik i direktor kompanije Tehnix, g. Đuro Horvat (1943-2023), bio je jedan od najvećih inovatora i izumitelja u Hrvatskoj i ovom dijelu Europe za što je primio stotine priznanja i odličja. Svi proizvodi, oprema i tehnologije kompanije Tehnix vlastiti su izumi i patenti g. Đure Horvata na kojima počiva uspješnost i razvoj kompanije Tehnix u svjetskog lidera na području zaštite okoliša i doprinosu smanjenja klimatskih promjena. Predani smo upravljanju našim poslovanjem na zakonit i odgovoran način, što uključuje poslovanje s partnerima koji poštuju ljudska prava, osiguravaju sigurna i inkluzivna radna mjesta i potiču održivu budućnost. To uključuje borbu protiv klimatskih promjena i zaštitu bioraznolikosti i ekosustava. Slogan kompanije Tehnix je: „Zadovoljan kupac je naš prvi poslovni interes“, što znači da je tržište najbolji partner, ako imate inovativan i kvalitetan te trajno funkcionalan proizvod. Na sljedećim stranicama želimo Vam predstaviti jedan dio Tehnix proizvodnje i razvoja koji se odnose na proizvodnju opreme i tehnologije za gospodarenje otpadom na održivi način, odnosno preskontejnera, rolokontejnera, reciklažnih dvorišta, pretovarnih stanica i opreme. Nadamo se da ćete pronaći potrebne informacije u ovoj brošuri te Vas ujedno pozivamo na zajedničku suradnju u budućnosti.





6 - 7
MODERNO KOMUNALNO VOZILO
10 - 22 m³



13
SLIM FIT
najuže vozilo u klasi za najširi spektar zadataka



18
MODEL: STARO ZA NOVO



8 - 9
MODERNO KOMUNALNO VOZILO
5 - 9 m³



14 - 15
EKOMUNAL SAMOPODIZAČ



19
DETALJI EKOMUNAL NADOGRADNJE



10 - 11
VELIKA EKOMUNAL VOZILA S KRANOM



16
EKOMUNAL DVOKOMORNO VOZILO 30/70



20
DIGITALIZACIJA I SPECIJALIZIRANA OPREMA EKOMUNAL VOZILA



12
MALA EKOMUNAL KIPER VOZILA S KRANOM



17
SPECIJALNA IZVEDBA VOZILA



21
OTPREMA VOZILA, MONTAŽA I TRANSPORT





17 razloga zašto kupiti komunalno vozilo EKOMUNAL

- Visoka kvaliteta vozila i nadogradnje EKOMUNAL 5 / 6 / 7,5 / 8 / 10 / 12 / 14 / 16 / 18 / 20 / 22 m³
- Dobra cijena, povoljni uvjeti nabave, trajna kvaliteta kompletnog proizvoda
- Osigurani rezervni dijelovi te servis vozila i nadogradnje, jamstvo 12, 24 i 36 mjeseci
- Mala potrošnja goriva, ušteda 30 % uz 20 % veći volumen prihvata otpada
- EURO 6E motor, štedi gorivo uz minimalno ispuštanje emisije CO₂
- Nadogradnja je trajna, skladna, kompaktna tipska konstrukcija
- Svi dijelovi brzo zamjenjivi i visoke kvalitete uz jamstvo trajnosti
- Ugrađen tlačno osjetljiv sustav za maksimalnu sabijenost otpada u prihvatnoj komori
- Sabijanje i izbacivanje otpada pomoću trostupanjskog teleskopskog cilindra
- Video nadzor bočno, iza i ispred vozila, kontrola i rasvjeta utovarnog prostora, sigurnost poslužioaca
- Automatsko ograničenje radne brzine i maksimalne brzine vozila
- Rad vozila i nadogradnje vrlo su tihi u radnim uvjetima
- Vršimo obuku vozača i poslužioaca EKOMUNAL vozila u poduzeću Tehnix
- Visoki standardi sigurnosti zaštite na radu
- Uz isporuku EKOMUNAL vozila dajemo kompletnu atesnu dokumentaciju i upute za korištenje i održavanje na hrvatskom jeziku
- Posjedujemo zamjensko vozilo u slučaju kvara
- Staro za novo



EKOMUNAL vozilo ispred TEHNIX izložbenog salona



Krstarenje EKOMUNAL 16 m³ vozila

TEHNOLOŠKE, EKONOMSKE I EKOLOŠKE PREDNOSTI NABAVE NOVOG EKOMUNAL VOZILA

1. Tehnološke prednosti nabave novog EKOMUNAL vozila:

- visoka kvaliteta vozila Mercedes omogućuje trajnu funkcionalnost u prikupljanju otpada
- automatski mjenjač štedi gorivo, motor i kvačilo, povećava učinak prikupljanja otpada i do 25 %
- ugrađeni zračni ovjes i amortizeri povećavaju stabilnost vozila, posebno na deponijama te kod isipavanja otpada
- nema ugrađeni hladnjak hidrauličnog ulja jer se hlađenje vrši preko specijalnog rezervoara sa prirodnim rashlađivanjem, time postizemo dugotrajnost korištenja hidrauličnog ulja
- nema začepjenja sača hladnjaka od insekata iz deponije
- ugrađen je sustav za amortizaciju stajališta poslužioaca
- radni proces prikupljanja i sabijanja otpada je kod 800 o/min
- ugrađen sustav za potpunu kontrolu prostora i sigurnost rada
- postigli smo nisku razinu buke, dugotrajnu funkcionalnost, sigurnost vozača i sigurnost poslužioaca

2. Ekonomske prednosti nabave novog EKOMUNAL vozila:

- manja potrošnja goriva do 20 % za prikupljeni komunalni otpad
- brzina prikupljanja otpada u naseljima i gradovima do 20 % veća
- automatski mjenjač brzina povećava brzinu i sigurnost upravljanja

- kočioni sistem daje sigurnost u brdskim uvjetima
- prikupljanje otpada iz kanti 80, 120, 240 litara, kontejnera 1100 l, 5 i 7 m³
- Mogućnost ugradnje teleskopskog kрана za pražnjenje podzemnih kontejnera na dvoosovinsko vozilo
- mogućnost pretovara otpada iz manjih vozila od 5 i 7 m³ u 16 m³
- standardizacija vozila, lakše, brže, ekonomičnije održavanje
- dajemo mogućnost zamjene staro za novo vozilo
- planiramo jeftinije servisiranje i održavanje vozila u jednom intervalu
- povoljna nabava vozila, leasing uz 2 % kamatu
- bitno jeftinije gospodarenje otpadom, manji trošak građanima

3. Ekološke prednosti nabave novog EKOMUNAL vozila:

- manje zagađenje zraka, smanjenje klimatskih promjena
- smanjeno zaustavljanje vozila kod prikupljanja otpada
- mogućnost prikupljanja predsortiranog i miješanog komunalnog otpada
- veća sigurnost u javnom prometu i prostoru
- ekonomičnija (rjeđa) zamjena hidrauličnog ulja i ulja iz motora
- potrebno je manje vozila za prikupljanje otpada
- potrebno je 20 % manje vozača i poslužioaca, kanti i kontejnera



EKOMUNAL volumena 14 m³, 20 500 kg



Pražnjenje 5 i 7 m³ komunalnih kontejnera



Pocinčani podizač za kante i kontejnere



Moderan dizajn i individualna vizualizacija



EKOMUNAL 12 podvozje i nadogradnja prema zahtjevu naručitelja



Visoka efikasnost sabijanja i jednostavnost pražnjenja

TIP NADogradnje	TLAČNA KOMORA (m ³)	USIPNA KOMORA (m ³)	DUŽINA (mm)	ŠIRINA (mm)	VISINA (mm)	NAJVEĆA DOPUŠTENA MASA (kg)	BROJ OSOVINA
EKOMUNAL 8	8	1	do 7100	do 2100	do 2900	8 550	2 (4+2)
EKOMUNAL 10	10	1,2	do 7750	do 2500	do 3200	13 500	2 (4+2)
EKOMUNAL 12	12	1,2	do 8250	do 2500	do 3200	13 500	2 (4+2)
EKOMUNAL 14	14	2	do 8500	do 2600	do 3400	18 000	2 (4+2)
EKOMUNAL 16	16	2	do 8800	do 2600	do 3400	18 000	2 (4+2)
EKOMUNAL 18	18	2	do 9500	do 2600	do 3400	26 000	3 (6+2)
EKOMUNAL 20	20	2	do 9900	do 2600	do 3400	26 000	3 (6+2)
EKOMUNAL 21	21	2	do 10 200	do 2600	do 3400	26 000	3 (6+2)
EKOMUNAL 22	22	2	do 10 400	do 2600	do 3400	26 000	3 (6+2)

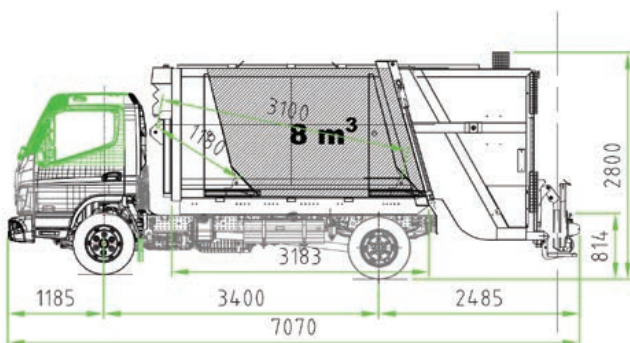

EKOMUNAL 8 m³



EKOMUNAL flota 16 m³ vozila

MODERNO KOMUNALNO VOZILO EKOMUNAL 5 - 9 m³



TIP NADOGRAĐNJE	USIPNA KOMORA (m ³)	DUŽINA (mm)	ŠIRINA (mm)	VISINA (mm)	NAJVEĆA DOPUŠTENA MASA (kg)	BROJ OSOVINA
EKOMUNAL 5	5	do 4800	do 1800	do 2800	3500	2
EKOMUNAL 6	6	do 5800	do 2000	do 2800	3500	2
EKOMUNAL 7,5	7	do 5700	do 2000	do 2950	7500	2
EKOMUNAL 9	9	do 6700	do 2200	do 3100	8550	2



Suvremena specijalizirana EKOMUNAL vozila 5 - 9 m³



Obuka djelatnika u realnim uvjetima



Rasklopna korpa za prikupljanje u vrećama

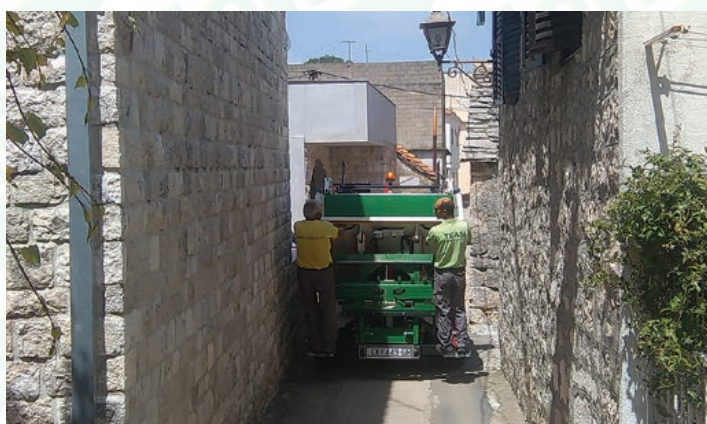

Primjer sakupljanja otpada - uske ulice i putevi Dalmacije



Pražnjenje pocinčanih 1100 l komunalnih kontejnera



Demonstracija velikih mogućnosti malih vozila



Podizanje PVC kanti i kontejnera



Mogućnost pretovara malih u velika vozila pomoću hidrauličnih produžetaka za potpunu preciznost i dodatnu čistoću



VELIKA EKOMUNAL VOZILA S KRANOM



EKOMUNAL 16 m³ s TEHNIX kranom



Vozilo za inozemnog kupca s TEHNIX kranom



Svježe završena montaža u tvornici EKOMUNAL vozila te isporučeno vozilo na zadatku pražnjenja zvonastih kontejnera



Niskopodna verzija kabine s jednom stepenicom; Low entry princip!



ECONIC - niskopodno vozilo s kranom u funkciji

TIP NADOGRADNJE	EKOMUNAL 16 s dizalicom Palfinger	EKOMUNAL 16 s dizalicom Tip Hyva	EKOMUNAL 16 s dizalicom Tip Tehnix
MAKSIMALNI DOHVAT (m)	7,7	7,0	7,7
PODIZNI MOMENT (kNm)	70	62	70
KUT ZAKRETA (°)	316	270	316
RADNI TLAK (bar)	240	250	240
VISINA KOMPLETNOG VOZILA (mm)	do 3950	do 3950	do 3950
TEŽINA DIZALICE (kg)	1100	750	1100
NOSIVOST NA MAKSIMALNOM DOHVATU (kg)	600	600	600

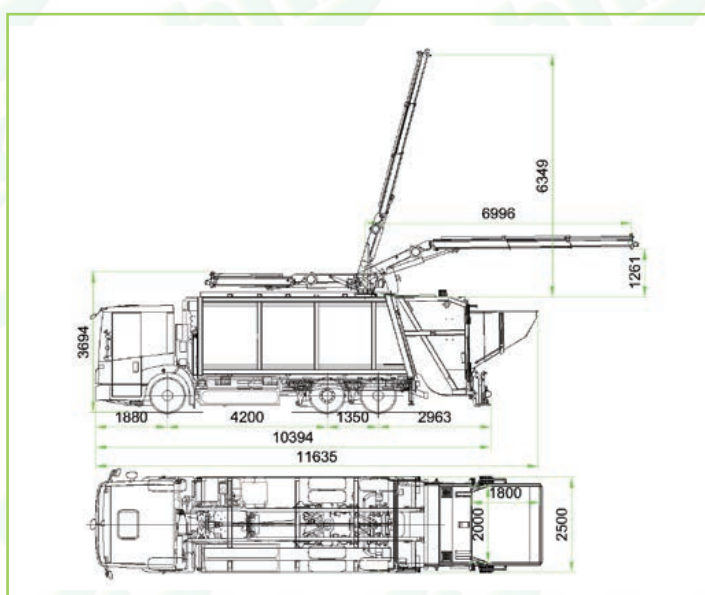



Posebni TEHNIX nastavci - montažno-demontažne stranice



TEHNIX grabilica kapaciteta 0,4 i 0,8 m³



EKOMUNAL za glomazni otpad - FASSI kran



Manevriranje kranom s radijskim upravljanjem

MALA EKOMUNAL KIPER VOZILA S KRANOM



EKOMUNAL 7,5 - podizač za kante i kontejnere te kran u funkciji



Specijalno vozilo prema zahtjevu naručitelja



PALFINGER



TEHNIX pruža tehničke odgovore na sve zahtjeve u prikupljanju otpada



TIP NADOGRADNJE	TLAČNA KOMORA (m ³)	USIPNA KOMORA (m ³)	DUŽINA (mm)	ŠIRINA (mm)	VISINA (mm)	NAJVEĆA DOPUŠTENA MASA (kg)	BROJ OSOVINA
EKOMUNAL 10	10	1,2	do 7750	do 2300	do 3200	13 500	2 (4x2)



Trag guma 2285 mm





PTP 10 - Podizanje preskotejnera s teleskopskim rukama

TIP NADOGRAĐNJE	DUŽINA (mm)	ŠIRINA (mm)	VISINA (mm)	NAJVEĆA DOPUŠTENA MASA (kg)	BROJ OSOVINA
PTP 5/7	do 5700	do 1800	do 2800	7 500	2
PTP 10	do 7000	do 2600	do 3500	13 500	2
PTP 12	do 7500	do 2600	do 3800	18 000	2





TEHNIX samopodizač sa zimskom službom



Daljinsko radio upravljanje

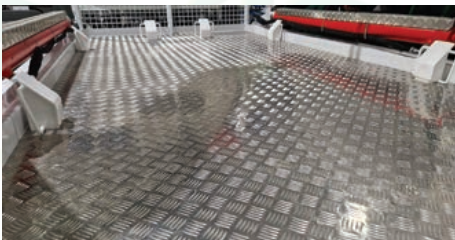

Detalji opreme i zaštita od udarca lancem

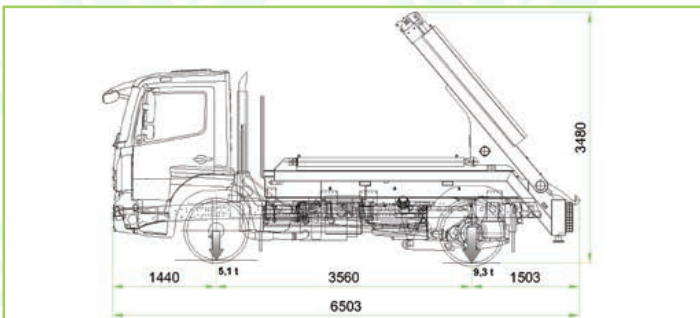

EKOMUNAL PTP 5/7



Vozila u proizvodnji spremna za isporuku

EKOMUNAL DVOKOMORNO VOZILO 30/70 - moguća drugačija raspodjela



Dvokomorno vozilo



Komore 1/3 i 2/3



Primjer rada male daske i lopate



Simultani rad obje komore

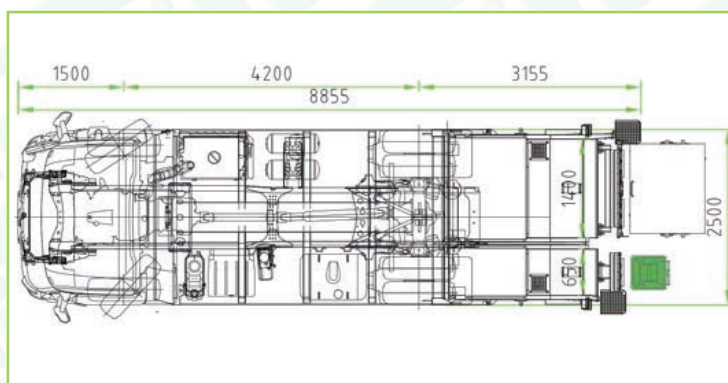

Primjer rada velike daske i lopate

TIP NADOGRADNJE	TLAČNA KOMORA (m ³)	USIPNA KOMORA (m ³)	DUŽINA (mm)	ŠIRINA (mm)	VISINA (mm)	NAJVEĆA DOPUŠTENA MASA (kg)	BROJ OSOVINA
EKOMUNAL 14	10+4	1,2+0,6	do 8500	do 2600	do 3400	18 000	2 (4+2)
EKOMUNAL 16	11+5	1,2+0,6	do 8800	do 2600	do 3400	18 000	2 (4+2)
EKOMUNAL 18	12+6	1,2+0,6	do 9500	do 2600	do 3400	26 000	3 (6+2)
EKOMUNAL 20	13+7	1,2+0,6	do 9900	do 2600	do 3400	26 000	3 (6+2)
EKOMUNAL 22	14+8	1,2+0,6	do 10 400	do 2600	do 3400	26 000	3 (6+2)



Trostrani kiper s alumijskom pocinčanom nadogradnjom, kranom i ceradom



Multifunkcionalni trostrani kiper s kranom na šasiji pogona 4x4 sa zimskom službom



Nadogradnja cisterne za pitku vodu i sve ostale namjene



Nadogradnja kran-navlakač



Kiper nadogradnje s kranom

MODEL - STARO ZA NOVO



Staro podvozje naručitelja



Servisirano podvozje i nova EKOMUNAL nadogradnja



Staro podvozje naručitelja



Servisirano podvozje i nova EKOMUNAL nadogradnja



Automatsko podmazivanje kliznih površina



Zaštitni kavez rotacijskih svjetala



Sustav za podizanje 5-7 m³ kontejnera



Oprema u skladu s cestovnim zakonom



Hidraulika Tehnix

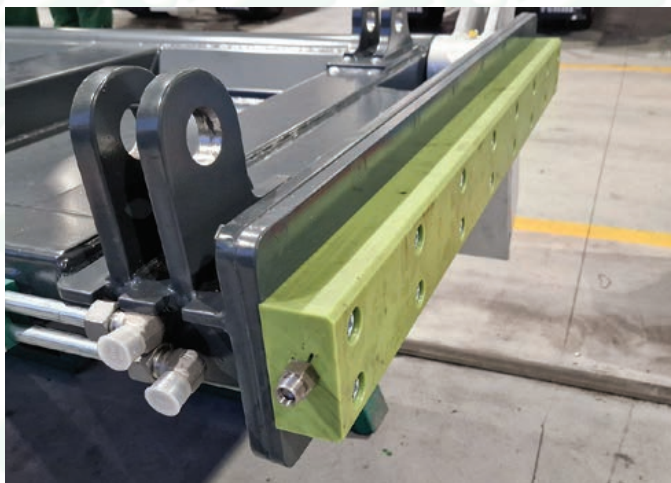

Visokokvalitetni samopodmazajući materijal



Specijalni odbojnik



Certificirani ortopedski amortizer



Drenažni ventil



Upravljački panel



Upravljanje pomoću mobilnog uređaja

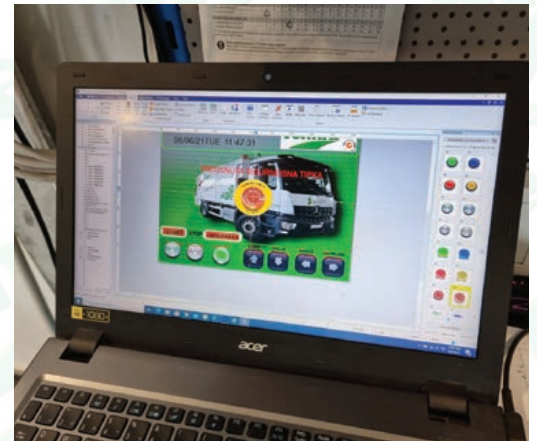

Internet dijagnostika



Sustav videonadzora



Radijsko upravljanje



Upravljački panel



Identifikacijski sustav - RFID i upravljački mehanizam EKOMUNAL nadogradnje

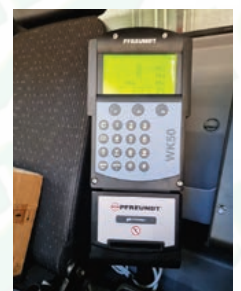
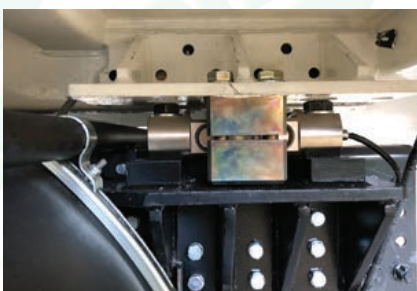

Ugradnja vage na EKOMUNAL vozila

Ispis vaganja

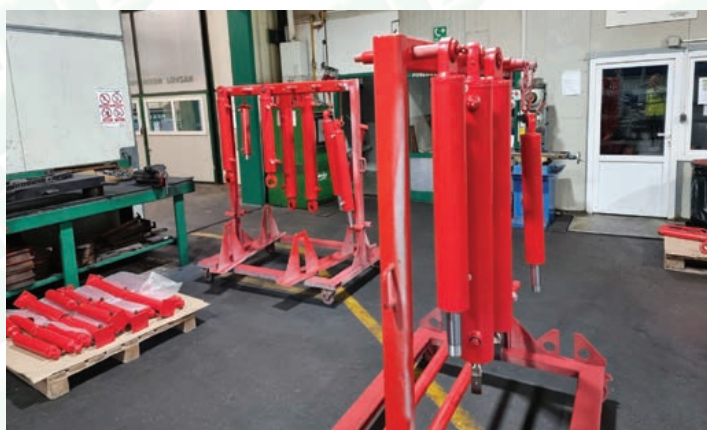

Ugrađeni cilindri tip Tehnix EKOMUNAL

Pocinčana i plastificirana lopata i daska

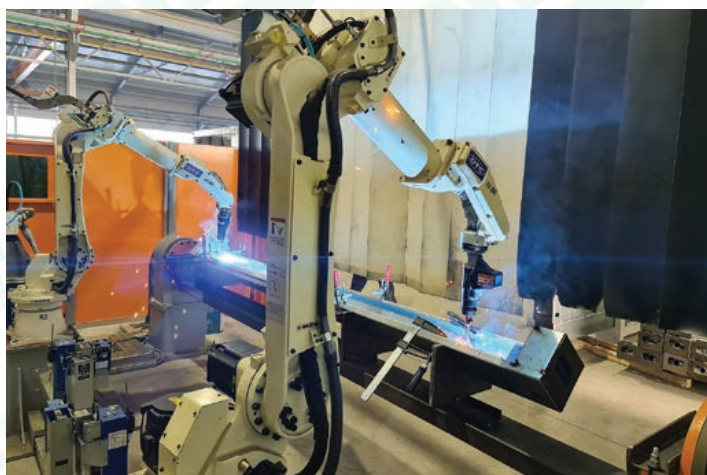

Robotsko zavarivanje i izrada naljepnica - brendiranje prema kupcu



Edukacija krajnjih korisnika u središnjici TEHNIXA i na terenu

Tehnix[®]

TEHNI^X d.o.o.

SJEDIŠTE KOMPANIJE

Ludbreaška 91a

40320 Donji Kraljevec

HRVATSKA

centrala: +385 40 650 100

komercijala: +385 40 650 101

tehnički ured: +385 40 650 111

e-mail: tehnix@tehnix.com

web: www.tehnix.com

OIB: 780 138 46 555



URED TEHNI^X ZAGREB

Krinski trg 14

telefon: +385 1 605 5896

GSM: +385 98 305 795

e-mail: zagreb@tehnix.com

URED TEHNI^X SPLIT

Držićeva 7, Solin

telefon: +385 21 244 739

GSM: +385 98 216 794

e-mail: splt@tehnix.com

URED TEHNI^X SLOVENIJA

Cankarjeva 6e

Maribor, SLOVENIJA

GSM: +386 41 619 828

e-mail: iztok.mirnik@tehnix.com

TEHNI^X BEO d.o.o.

Bulevar Peka Dapčevića 55

Beograd, SRBIJA

centrala: +381 11 3978-775

fax: +381 11 3978-776

e-mail: beograd@tehnix.com

web: www.tehnixbeo.rs

*Ja sam prijatelj
Tehnika*

