

Presjek A-A

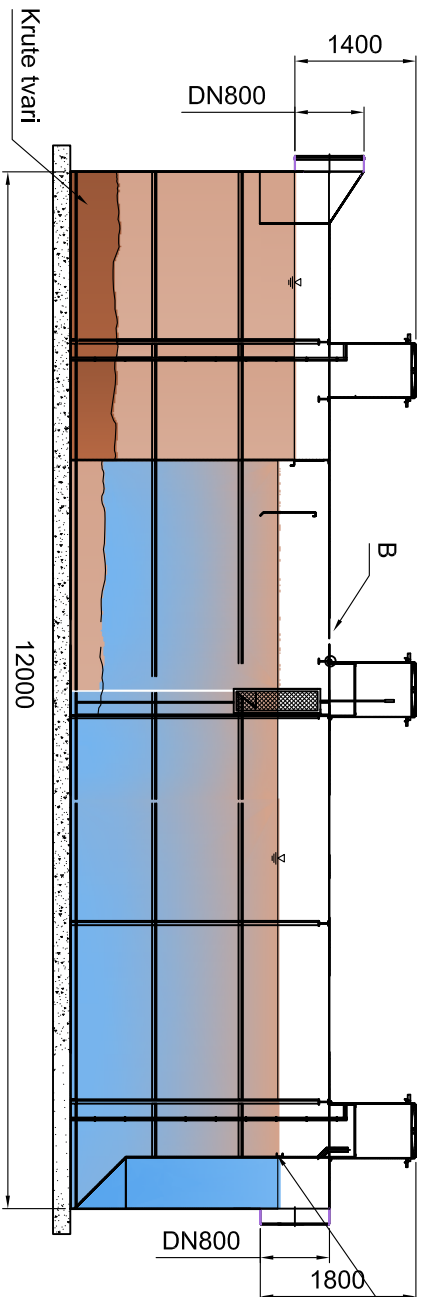

Kontrola opterećenosti

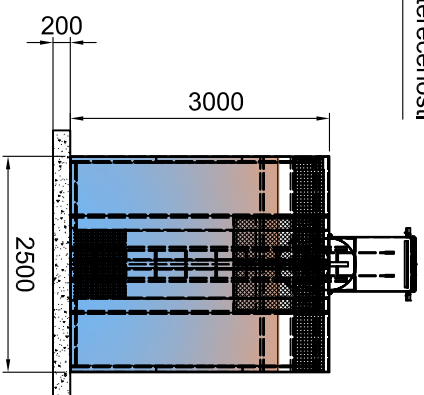

Detaji B
Mjerilo 1:5

Regulacija kliznih
grla vijcima M12x25

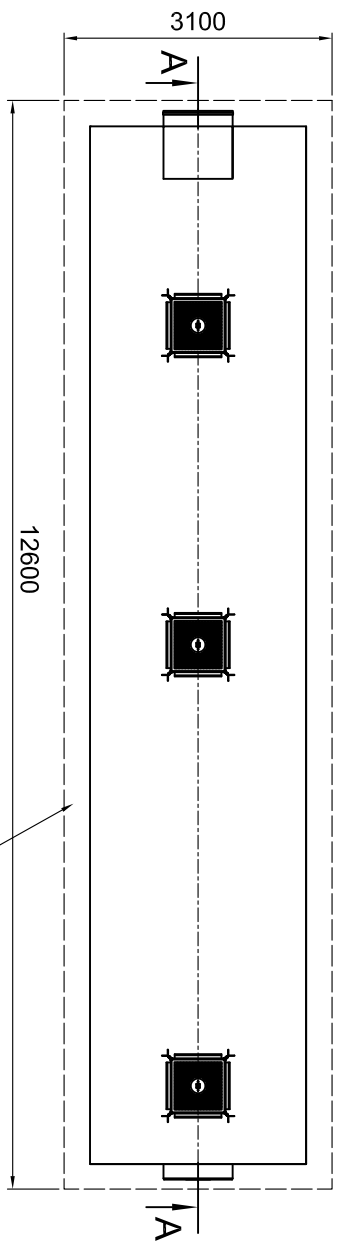

AB podloga

Čelčni
anker

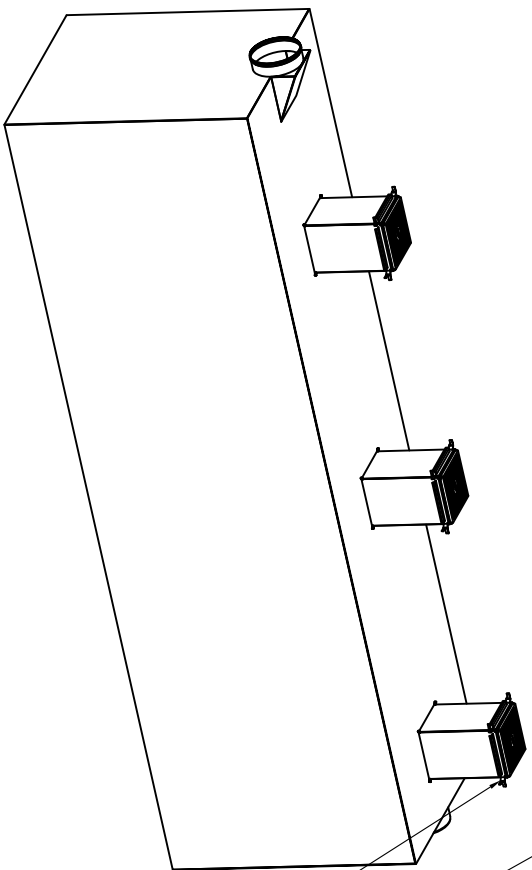

Separatori spadaju u I. klasu separatora prema hrvatskoj normi HRN EN 858 što znači da je količina rezidualnog ulja manja od 5 mg/l

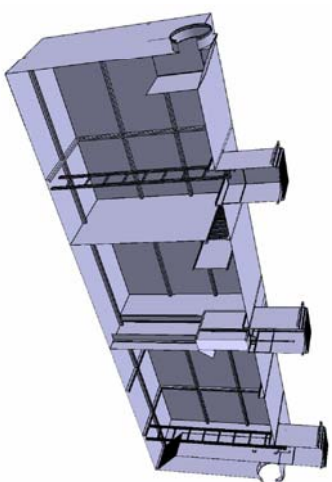

Polipropilenski
koalescentni
uložak

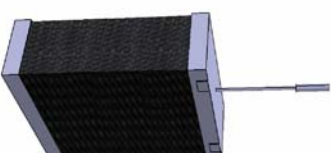

Volumen separatora: 80000 l
Protok separatora: 300 l/s
Cijevi: Ø800
Masa praznog separatora: 10900kg
Masa punog separatora: 80000kg

Površina	Mjerilo	1:60	Pozicija	-	Masa	-

Ime	Datum	Potpis
Levačić Ildipling, str.		
Horvat D.maring, mech.		
Horvat Dj, str.leh, acc		
Čiao		
Prekontl		
Odobrio		

Separator 80000

Q=300 lit/sec

Tehnix

TX-DK-D-1907-SEP-80000-S1

radbri Promjena Datum Ine Spremljeno TX-DK-D-1907-SEP-80000-S1

Page Pg

